

Turning and Detailing Platter Bases

Andy Gunning - Instructor

Introduction

Turning platters offers an excellent opportunity to express yourself creatively and to use an infinite variety of designs and surface treatments. I have found that designing and detailing the bases on my platters is as enjoyable as detailing the front of the platters. There are four types of bases that I turn: 1) a round base, 2) a three footed base, 3) a multi-axis base, and 4) a three footed multi-axis base. There are a multitude of variations of each of these bases. The following are the steps that I use to create and detail each of these bases. I use pyramid, spiraling, knurling and texturing tools to enhance the platters, both front and back. The platter bases shown are examples of the four types of bases that I turn and will be described in this handout.



Rounded base



Three footed base



Multi-axis base



Three footed multi-axis base

NOTE:

There are a number of steps that are common to turning any of the four type of bases featured in this handout. In order to limit the number of pages of this handout, these steps will not be repeated once I have described them. I will begin with the round base followed by the three footed base, then the multi-axis base and finally the multi-axis three footed base.

Platter Blank

Kiln dried wood or wood that has been air dried for several years is recommended for turning platters. I have found that platters turned with dry wood will not warp after they have been turned, as is often the case with using green wood.

I use many kinds of wood for my platters, however, when turning natural edge platters my favorite is burl wood especially big leaf maple burl. When coloring platters light woods such as maple, ash or poplar work well. I use wood that is 2" thick, although 1 1/2" thick wood can be used. My preferred method for chucking platter blanks is with expansion chucking. This chucking method works well with platters up to 24". The same type of bases and chucking method that I use for my platters can just as easily be use when turning bowls.

I. Turning a Round Base

I use a round base most often on my larger platters. I try to keep the outer edge of the foot equal to 1/3 the size of the platter, therefore it is sometimes necessary to turn a double foot with a recess for chucking within the inner foot. A round foot can be made quite attractive with beading and texturing.

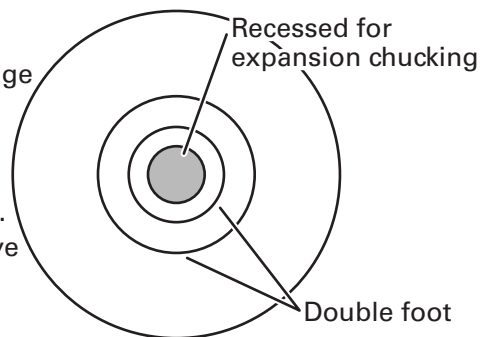

Tools

1. 3/8" bowl gouges with fingernail and traditional grinds
2. 1/4" skew chisel
3. 1/4" Pyramid tool
4. Texturing tool
5. Knurling tool
6. Spiraling tool



I. Select platter blank

1. Dry wood, preferably kiln dried.
2. Blanks are 1 1/2" to 2" thick and from 9" to 24" square.
3. Check the wood for defects as well as for character.
4. The most interesting side is used for the front.

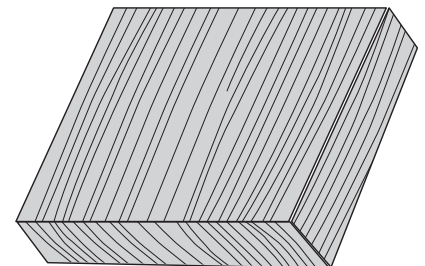

II. Prepare blank

1. Plane the face of the blank if uneven so that the faceplate or woodworm screw, when chucked, will sit evenly.
2. Draw a circle on the blank with a compass to determine the largest diameter possible.
3. Cut the corners of the blank on a band saw in order to facilitate turning the blank on the lathe.

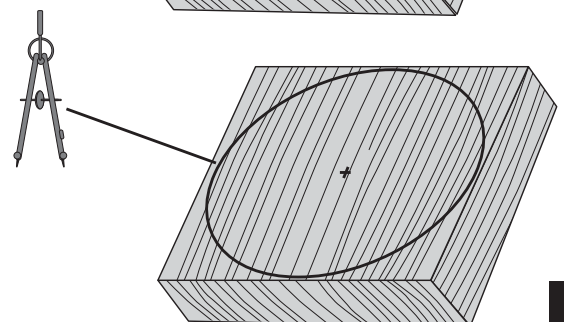

Turning a Round Base (continued)

III. Mount the Blank

1. Mark the center point on the front of the blank.
2. If using a faceplate, align the faceplate in the center of the blank.
3. Mark and pre-drill the holes for the faceplate. A 3" faceplate for blanks up to 12" and a 6" faceplate for larger blanks is recommended. The faceplate is attached with 1" long #10 machine screws.
4. If using a woodworm screw, drill a 3/8" hole 3/4" deep in the center. I use an Oneway woodworm screw; other screws may require a different size hole. For 1 1/2" thick wood I drill a 5/8" deep hole and use a 1/8" thick spacer.
5. Place the woodworm screw in a four jaw chuck and mount the blank on the lathe.
6. True up the edge and base of the blank.

NOTE: On platters larger than 11", I turn and detail the rim on the front of the platter while it is still mounted on the woodworm screw. If the back of the platter is completed before the rim is completed, the resulting thinness of the rim makes it difficult to detail it.

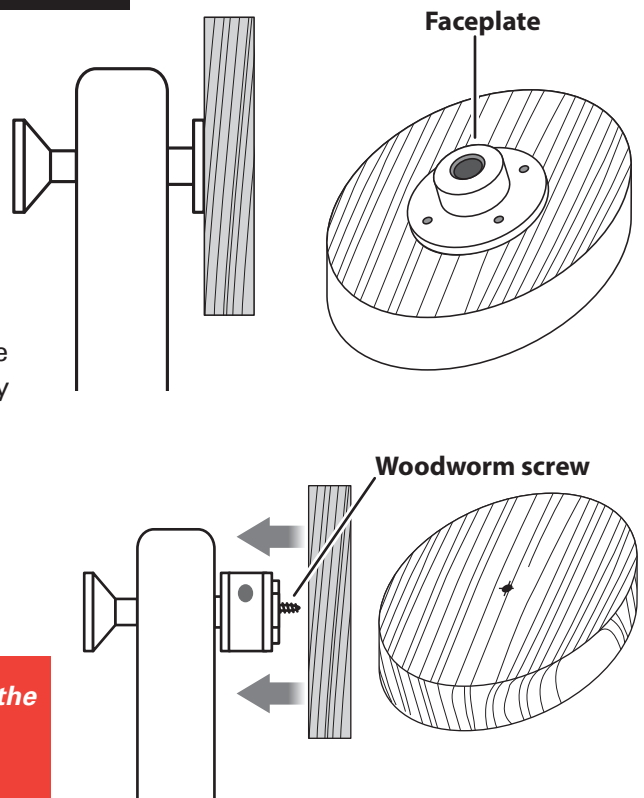

IV. Preparing the recess and foot

Now that you have selected, prepared the platter blank, mounted it on the lathe with a faceplate or woodworm screw and turned up the edge and back, you are ready for the first steps in turning the base of the platter. These steps will involve preparing the recess and foot, turning the foot and base, and finally detailing the foot and base.

Note: There are two sizes of recesses and feet that I turn, depending on the size of the platter.

Platters 12" or smaller

Draw 1" radius and 2" radius circles in the center of the base of the blank to create a 1" wide band; this will be your platter's foot. (This will give you a 4" foot.) The space inside the 1" radius circle is recessed 3/8" for expansion chucking using a Talon chuck with number 2 jaws.

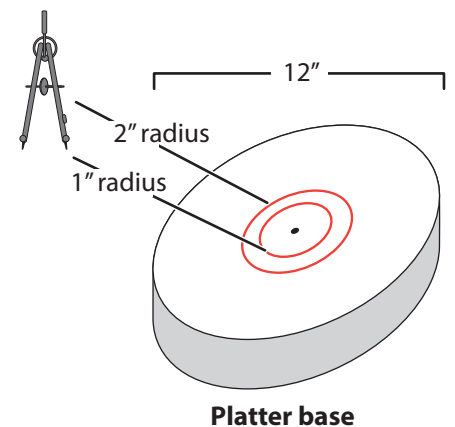

Platters 14" or larger

Draw 2" radius and 3" radius circles in the center of the base of the blank to create a 1" wide band; this will be your platter's foot. (This will give you a 6" foot.)

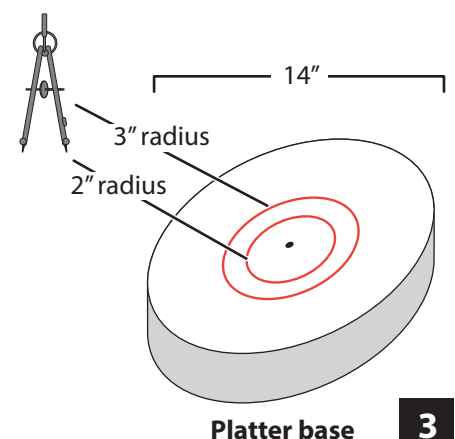

It is important that the sides of the recess are straight for expansion chucking if using straight jaws or dovetailed if using dovetail jaws. I prefer the expansion method because when I finish turning the base, I do not need to rechuck the platter to complete the foot. The foot and base are completed before turning the front of the platter.

Note: I use a Stronghold chuck with #2 jaws.

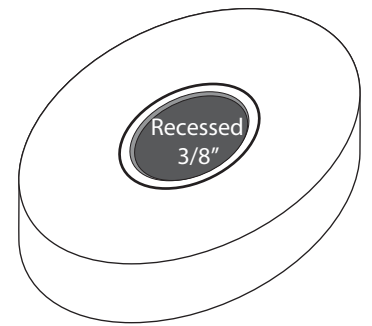

V. Turn foot and base

1. Rough turn the shape of the base of the platter from the outer circle of the foot to the edge of the blank. I like to create a slight ogee near the edge of the blank. Leave the foot approximately 3/8" proud of the surface of the base.
2. Refine the shape of the platter base and foot.
3. Sand the recess, foot and base of the platter to 320 grit.

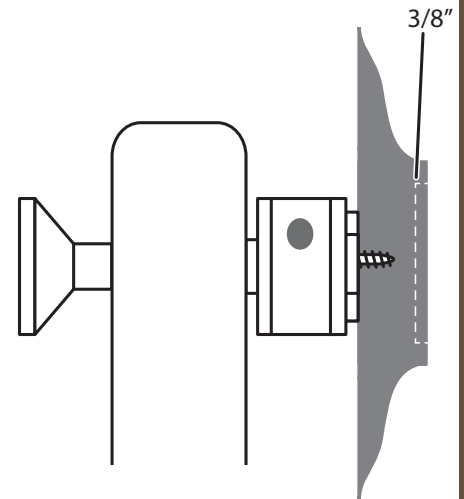

VI. Detailing

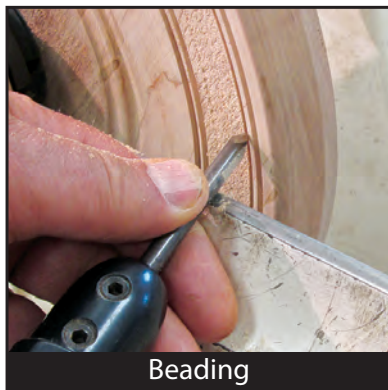

Beading



Texturing



Finished foot and base

Once the foot and base of the platter have been turned and sanded to 320 grit, detail the foot, base, and recess. I use a 1/4" Pyramid tool to turn beads and a knurling, texturing and spiraling tools to enhance the surface of the base, foot and recess.

1. After completing the texturing, carefully finish sanding with 400 to 600 grit.
2. Remove the blank from the lathe.
3. Remove the faceplate or woodworm screw from the blank.
4. Remount the blank on the lathe by expanding the chuck jaws into the recess to turn the front of the platter.
5. You are now ready to turn the front of the platter



Detailing Tools: Knurling, texturing, spiraling and Pyramid.

II. Turning a Three Footed Base

Turning a three-footed base is very similar to turning a round base. Basically, what is done is to turn a round base and then carve three feet in the foot. The size and design of the feet will vary to suit your taste.

I. Preparation steps

1. Mount the blank. For a 14" or larger blank draw the 2" and 3" radius circles for the foot as described earlier on pages 2-4.
2. Draw a third 2 1/2" radius circle in the center of the first two circles.
3. Use the radius of this center circle to divide the 1" wide band into thirds. This is done by marking a line anywhere on the center circle and using the compass set to the radius of the center circle to make five additional equally spaced lines. Mark every other line. You now have divided the circle into thirds.

Note: The radius of a circle is equal to about 1/6th its circumference.

4. Mark a line 3/4" on either side of each of the three points on the band. These will be the three 1 1/2" areas to be carved to create the feet.

NOTE: On platters larger than 11", I turn and detail the rim on the front of the platter while it is still mounted on the woodworm screw. If the back of the platter is completed before the rim is completed, the resulting thinness of the rim makes it difficult to detail it.

II. Turn the Foot and Base of the Platter

1. Recess the 2" radius circle to a depth of 3/8". This will be used for expansion chucking the blank when turning the front of the platter. It is important that the sides of the recess are straight for expansion chucking if using straight jaws or dovetailed if using dovetail jaws.
2. Rough turn the shape of the rest of the base of the platter from the 3" radius circle to the edge of the blank. I like to create a slight ogee near the edge of the blank.

III. Carving the Feet

1. I use a long neck grinder to carve the feet. A reciprocating carver works, but is slower.
2. Remove wood between the lines with the grinder using a medium disc.
3. Smooth the space between the feet with the grinder very carefully.
4. Refine the shape of the platter base.
5. Sand the recess foot and base of the platter to 320 grit.



IV. Detailing the Platter Base

At this point, I detail the foot, base, and recess of the platter. See the above section on detailing the platter base. Remount the blank on the lathe by expanding the chuck jaws into the recess in the foot of the platter to turn the front of the platter.

Finished base

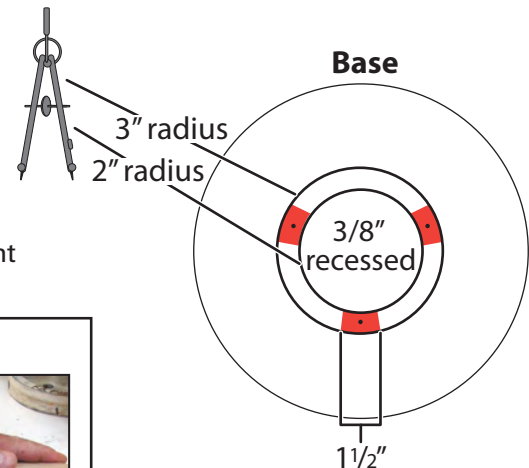
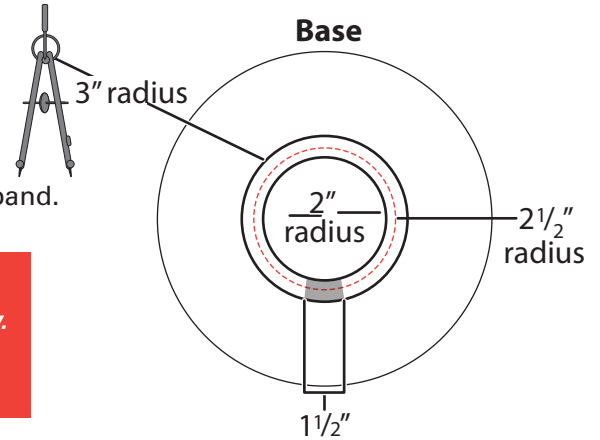

Finished base

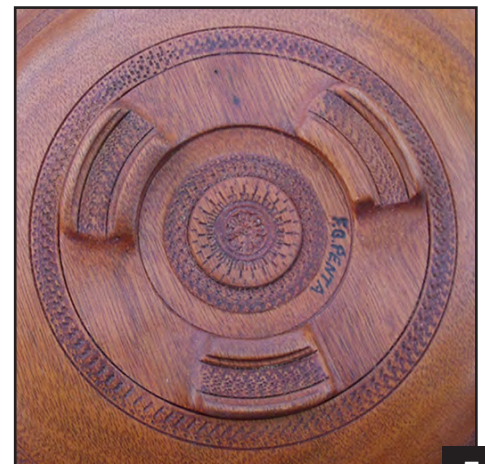

III. Turning a Multi-axis Base

I turn two sizes of multi axis bases. For platters that are 14" or larger, I turn a 9" (4 1/2" radius) multi axis base, for platters less than 14" I turn a 6" (3" radius) multi axis base.



I. Prepare the Platter Front to Turn a 9" Multi-axis Base

1. Draw a 1" radius circle in the center of the platter front.
2. Divide the circumference of the circle into thirds. Use the radius of this circle to divide the circle into thirds.
3. This is done by marking a line anywhere on the circle and using the compass to make five additional equally spaced lines. Mark every other line. You now have divided the circle into thirds.
4. Drill 3/8" holes 3/4" deep for your screw chuck in the center of the platter and at each of the three points on the circle. Number the holes on the 1" radius circle 1, 2 and 3.
5. Use an Oneway screw chuck; other screw chucks may require a different size hole. For 1 1/2" thick wood I drill a 5/8" deep hole and use a 1/8" spacer between the blank and the screw chuck.
6. I use a screw chuck in the center hole to mount the platter blank on the lathe and true it up.
7. With the blank mounted in the center hole and the edge turned, you are now ready to turn the foot and base.

Front

1" radius

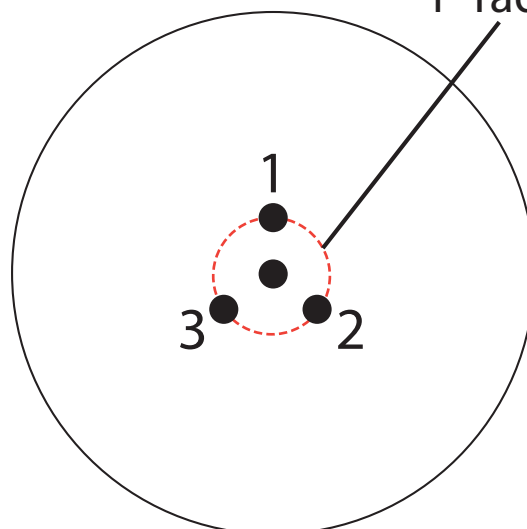

Note:

Drill (4) 3/8" holes 3/4" deep.

II. Turning the Foot and Base of the 9" Multi-axis Platter

1. Draw a 4 1/2" radius circle on the base. This will be the 9" circle around the foot of the platter.
2. Turn the shape of the rest of the base of the platter from the 9" circle to the edge of the blank. I like to create a slight ogee near the edge of the blank, leaving the 9" circle 3/8" proud of the base.

NOTE: On platters larger than 11", I turn and detail the rim on the front of the platter while it is still mounted on the woodworm screw. If the back of the platter is completed before the rim is completed, the resulting thinness of the rim makes it difficult to detail it.

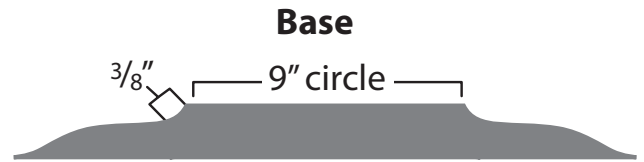

III. Turning the Base of the 9" Multi-axis Platter

1. Draw a 2 1/8" radius circle and a 1 3/4" radius circle on the base.
2. Turn a channel 1/4" deep between the 2 1/8" radius and 1 3/4" radius circles. This will be used for expansion chucking the blank when turning the front of the platter. It is important that the sides of the recess are straight for expansion chucking if using straight jaws or dovetailed if using dovetail jaws.
3. Remount the platter blank in hole #1 on the front of the platter.
4. With a live center in the tailstock, bring it up to mark a new center on the base.
5. Draw 2 3/4" radius and 3 1/8" radius circles around this new center.
6. Turn a channel 1/4" deep between these circles.
7. The new channel should coincide with the first channel where they overlap.
8. Repeat steps 4-7 with holes #2 and #3.
9. Remount the blank in the primary center hole
10. Take a light cut slanted from the edge of the foot to the center so that the platter will be sitting only on the outer edge of the foot.
11. Turn the center channel down an additional 1/8" for more secure expansion chucking.
12. Refine the shape of the platter base.
13. Sand the recess, foot and base of the platter to 320 grit.

Base

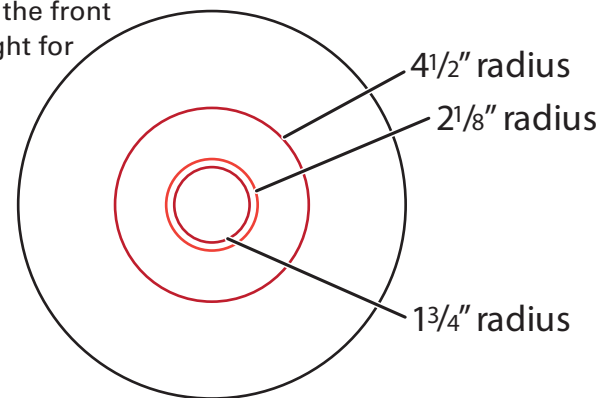

Base

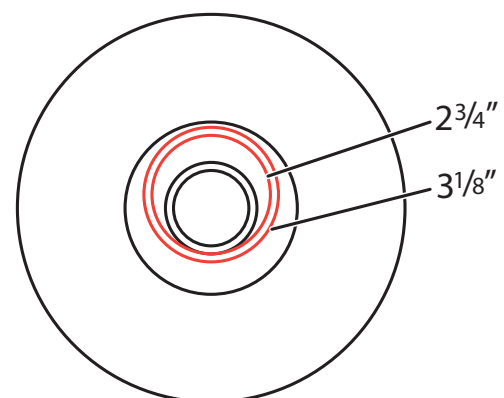

Multi-axis base

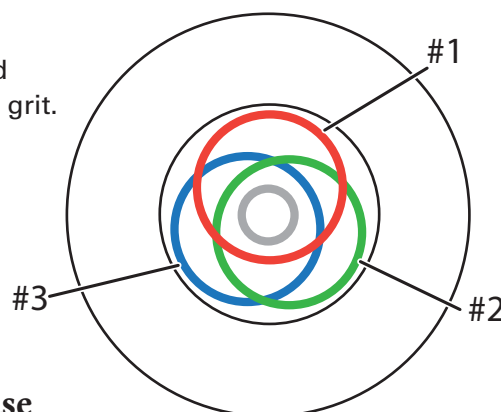

Detailing the Platter Base

At this point, I detail the foot, base, and recess of the platter. See the above section (page 4) on detailing the platter base. I sometimes texture the multi-axis base itself by rechecking it in the holes 1, 2 and 3 on the front of the platter. I use a texturing tool to texture each of the three channels.

1. After completing the texturing, carefully finish sanding with 400 to 600 grit.
2. Remove the blank from the lathe.
3. Remove the wood worm screw from the blank.
4. Remount the blank on the lathe by expanding the chuck jaws into the recess to turn the front of the platter.
5. You are now ready to turn the front of the platter

I. Prepare the Platter Front to Turn a 6" Multi-axis Foot

1. Draw a 5/8" radius circle in the center of the platter front.
2. Divide the circumference of the circle into thirds. Use the radius of this circle to divide the circle into thirds.
3. This is done by marking a line anywhere on the circle and using a compass to make five additional equally spaced lines. Mark every other line. You now have divided the circle into thirds.
4. Drill 3/8" holes 3/4" deep for your screw chuck in the center of the platter and at each of the three points on the circle. Number the holes on the 5/8" radius circle 1, 2 and 3.
5. I use an Oneway screw chuck; other screw chucks may require a different size hole. For 1 1/2" thick wood I drill a 5/8" deep hole and use a 1/8" spacer
6. Use a screw chuck in the center hole to mount the platter blank on the lathe and true it up.

Finished base

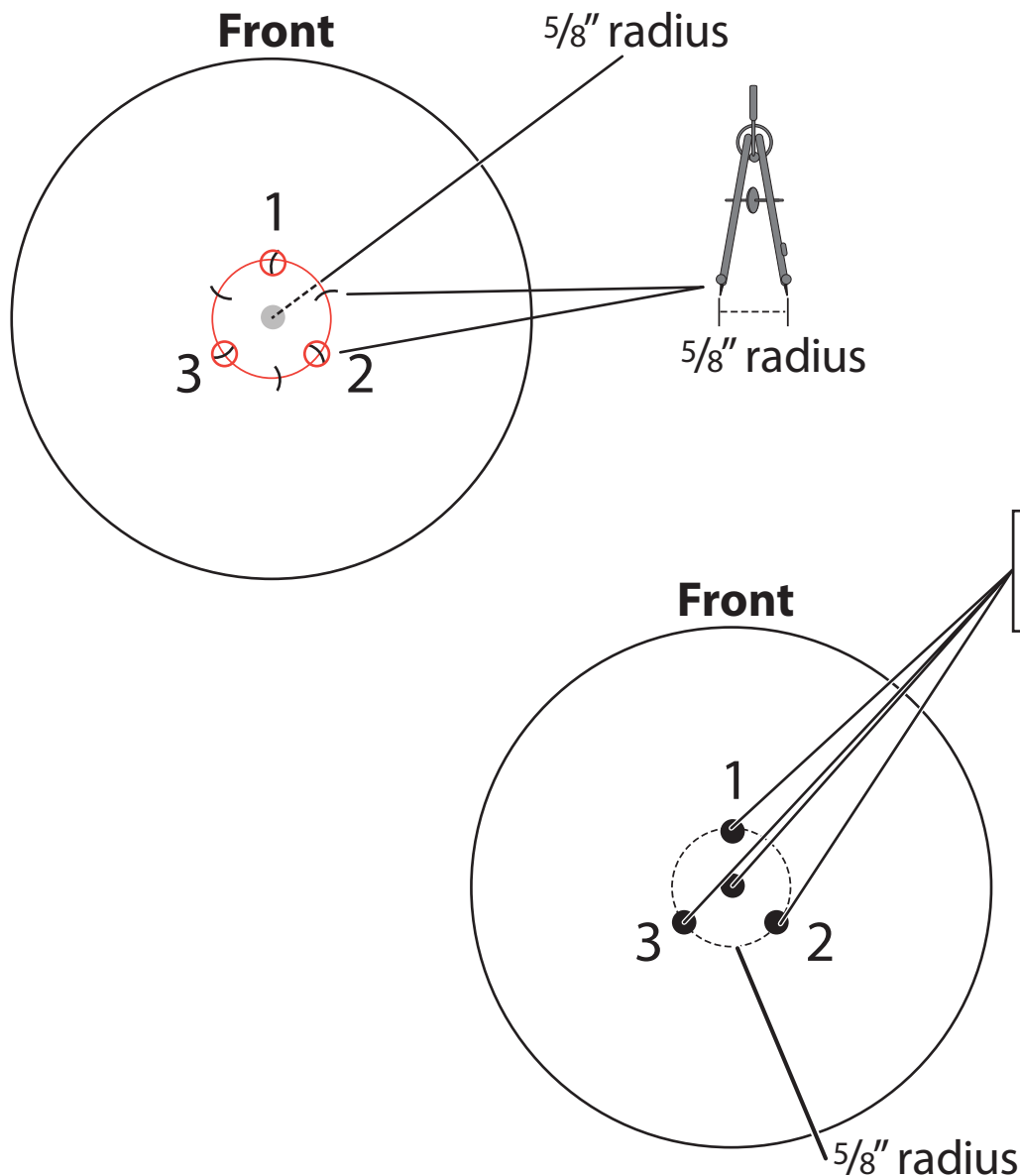

II. Turning the Foot and Base of the 6" Multi-axis Platter

1. Draw a 3" radius circle on the base. This will be the 6" circle around the foot of the platter.
2. Turn the shape of the rest of the base from the 3" radius circle to the edge of the blank. I like to create a slight ogee near the edge of the blank, leaving the 6" circle 3/8" proud of the base.

NOTE: On platters larger than 11", I turn and detail the rim on the front of the platter while it is still mounted on the woodworm screw. If the back of the platter is completed before the rim is completed, the resulting thinness of the rim makes it difficult to detail it.

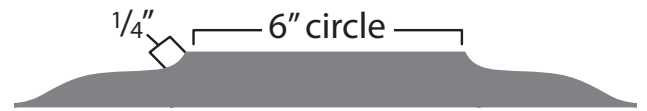

III. Turning the Base of the 6" Multi-axis Platter

1. Draw a 1" radius circle and a 1 3/8" radius circle on the base.
2. Turn a channel 1/4" deep between the 1" radius and 1 3/8" radius circles. This will be used for expansion chucking the blank when turning the front of the platter. It is important that the sides of the recess are straight for expansion chucking if using straight jaws or dovetailed if using dovetail jaws.
3. Remount the platter blank in hole #1 in the front of the platter.
4. With a live center in the tailstock, mark a new center on the base.
5. With a compass draw a 1 5/8" and 2" radius circles around this new center.
6. Turn a channel 1/4" deep between these circles
7. The new channel should coincide with the first channel where they overlap.
8. Repeat steps 4-7 with holes 2 and 3.
9. When completed turning the channels for holes 1, 2 and 3, remount the blank in the primary center hole.
10. Take a light cut from the edge of the foot to the center so that the platter will be sitting only on the outer edge of the foot.
11. Refine the shape of the platter base.
12. While the platter is remounted in the center hole, lower the depth of the center recess by 3/16".
13. It is essential that the center channel be at least 3/16" lower than the rest of the multi-axis channels. The three points on the 6" base are not big enough to withstand the pressure of the expanded chuck jaws.
14. Sand the recess foot and base of the platter to 320 grit.

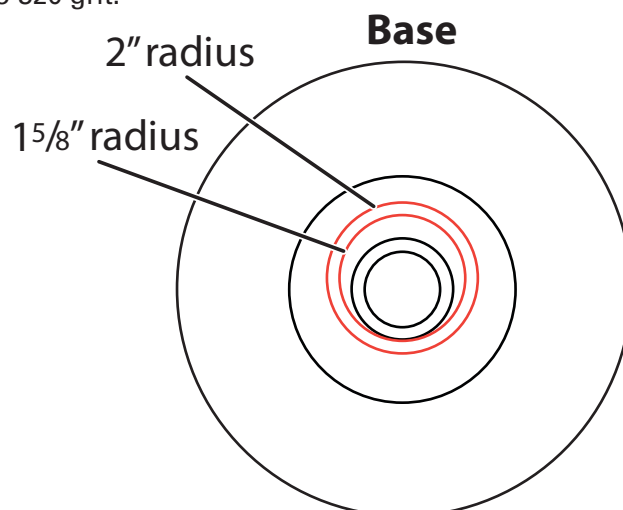
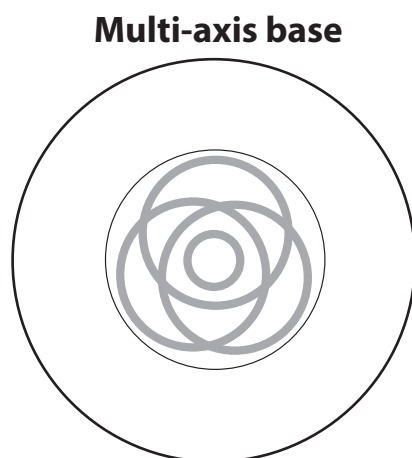
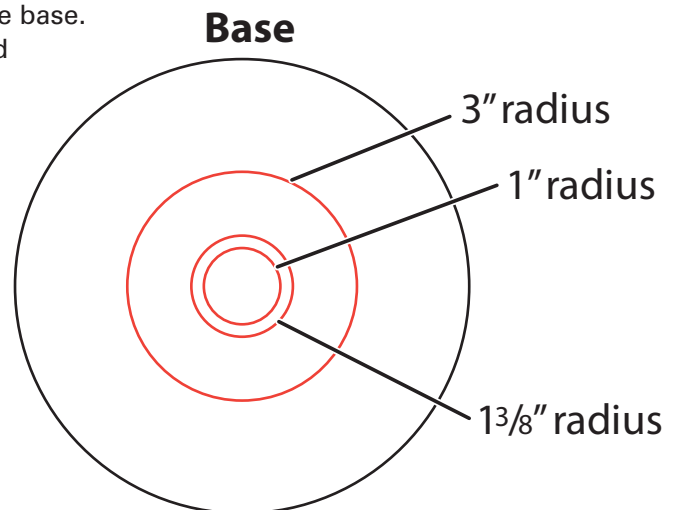

IV Turning a Three Footed Multi-axis Base

Turning a three-footed multi-axis base is very similar to turning a three footed base.

1. Complete steps in turning a multi-axis foot.
2. Place three equally spaced marks on the outer edge of the multi-axis foot.
3. Draw a line $\frac{3}{4}$ " on both sides of each of the three marks on the rim. These will be the three $1\frac{1}{2}$ " areas to be carved to create the feet.
4. Complete steps described in carving a three footed base.
5. Detail the platter and remount the chuck in the recess to turn the front of the platter.

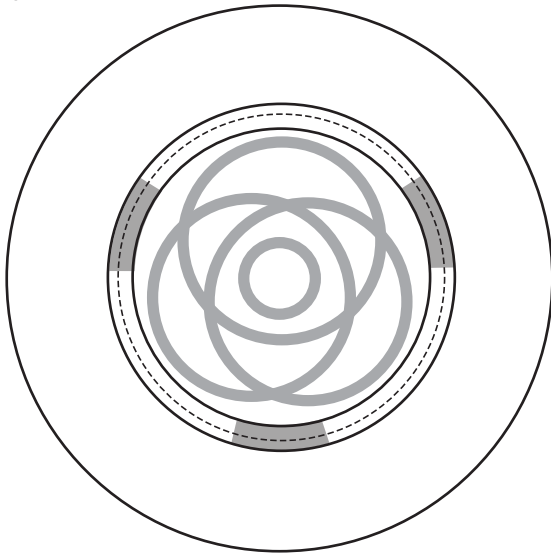

Finished base



Finished base



Finishing the Platter

No matter which base you turn, proper finishing will preserve and enhance the completed platter. When adding color, I use water based dyes, inks, or transparent acrylics before applying the finish. I use an oil/varnish mix on my platters. The oil/varnish mix consists of 1/3 pure tung oil, 1/3 polyurethane and 1/3 mineral spirits.

Note: *The most important part of finishing is a thorough and careful sanding job.*

